



AST **Modular** *General Catalogue*



AST Modular

AST Modular is the leading global provider of SECURE, MODULAR and ENERGY EFFICIENT IT infrastructures.

AST Modular has achieved over 20 world patented innovations in Secure and Modular Data Centers.

AST Modular is a global supplier to leading organizations in such sectors as: IT, finance, distribution, oil and gas, pharmaceutical, government, scientific, energy, machinery, construction, transportation, retail.

AST Modular employs over 40 specialist design and consulting Engineers to adapt our solutions to your data center needs.



PRODUCTS

Secure, Modular and Energy Efficient
Solutions for Data Center.

SMART DATA SAFE ®



Protect your organization's most critical asset: YOUR DATA

SDS is a compact, secure, plug & play Data Storage Solution (black box). It protects: YOUR DATA and it provides the fastest and most effective data recovery in a secure environment.

The SMART DATA SAFE ® incorporates an internal NAS (up to 10TB storage capacity in 5 SATA disks) for any company's backup data.

IDEAL FOR

Secure storage solution	Remote monitoring and status report
Heavy duty construction	Plug and play solution

SMART BUNKER



A rack with the same level of protection and functionality as a secure data center.

Standard dimensions are 23U and 46U 19" rack encapsulated in a "box within a box" design, with extremely efficient thermal insulation guaranteeing full protection for the internal services and IT equipment against fire, flood, vandalism, theft and EMF.

Specially designed to protect your IT against fire, water, theft, vandalism, EMF, etc.

It comes with integrated remote monitoring software including environmental parameters such as temperature, humidity, vibration, flooding, power.

In case of any alarm being activated, the machine will send a notification via SMS and/ or email and will automatically switch itself off, protecting the data stored inside.

IDEAL FOR

Secure	Total insulation: silent and thermally efficient
Heavy duty construction	Multiple cooling solutions

SMART COLD / HOT CORRIDOR



Flexible, easy to install, cold aisle insulation with very quick ROI.

Smart Cold/Hot Corridor increases the potential life span of the data center, enabling higher density computing. It insulates the cold air aisle from the hot air aisle and it saves energy.

The Smart Cold/Hot Corridor effectively improves the efficiency of the air conditioning blown into the IT racks (cold corridor), which means immediate savings in the operational costs of any data center.

IDEAL FOR

Modular design for flexibility

Can be adapted to any cold/hot aisle configuration

Easy to install

Low cost solution with very quick ROI

PUE Meter

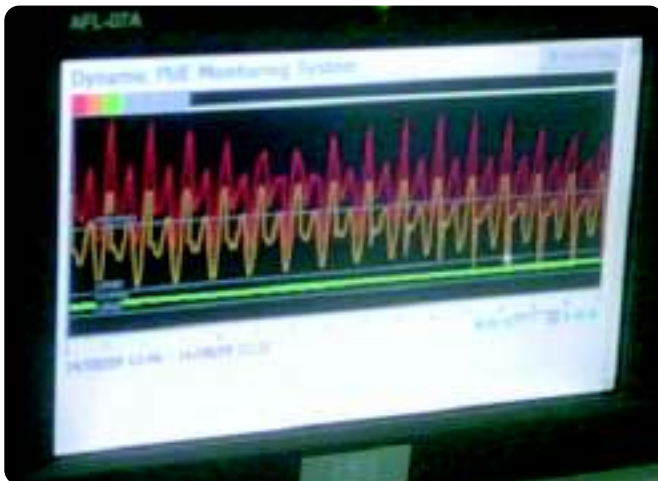

PUE Meter offers a complete (live) assessment of data center performances, delivering confidence and real time results on the energy consumption of your data center.

Based on PLC infrastructure PUE Meter is a daily tool that resolves weaknesses, improves efficiency, ensures system availability, and generates savings.

PUE Meter provides real time monitoring and measurements of your critical facility and it provides evidence of where the energy is consumed and where the opportunities for savings really lie:

Key facts:

- PUE
- Energy consumption (kW/h) and real cost in €.
- CO2 emissions (Tons) according to power source.
- Temperature
- Cold aisle
- Cold chilled circuit: inlet and outlet temperatures.
- Temperature of returning air back into the CRAC units.
- Status of CRAC units if ON or OFF.
- UPS load level

IDEAL FOR

Calculate data center PUE
Reduce data center energy costs

Monitor Data Center energy consumption
Live Installation



SOLUTIONS

Highly Energy Efficient, Secure and Modular.

SMART SHELTER+



The most secure modular IT Room.

SMART SHELTER+ provides unique advantages in terms of security, fast deployment and modularity, ensuring perfect environmental conditions for mission-critical IT Rooms and offering protection against any external hazards or natural disasters.

IDEAL FOR

Modular	Fast deployment
Security	Fulfills most demanding standards

SMART SHELTER



High Performance, Modular and Secure IT Room.

SMART SHELTER provides a good balance between the need for superior technical standards and the investment required and therefore it is a highly cost efficient product for IT Security Rooms.

IDEAL FOR

Modular	Fast deployment
Energy efficient	High Technical performance

SMART SHELTER LC 120



Cost-effective, Secure, modular room: a real alternative to traditional built.

Modular and easy to deploy LC 120 provides a protected environment for IT equipment at a very reasonable cost. LC120 can be installed indoors as well as outdoors, allowing modular deployment and future expansion.

IDEAL FOR

Cost Effective	Modular
Plug and play	Reduced delivery Time

SMART SHELTER CONTAINERS



Total Flexibility and Security in a Modular Data Center

Smart Shelter Containers provide a fully functional Data Center inside a regular ISO container infrastructure including: cooling, power, structural protection, fire protection, monitoring, access control, etc, achieving a total plug and play solution within a secure environment at the lowest PUE.

IDEAL FOR

- Friendly to the Environment
- Short Delivery Time
- Energy Efficient
- Hardware Neutral

COOLING BLOCK, NATURAL FREE COOLING

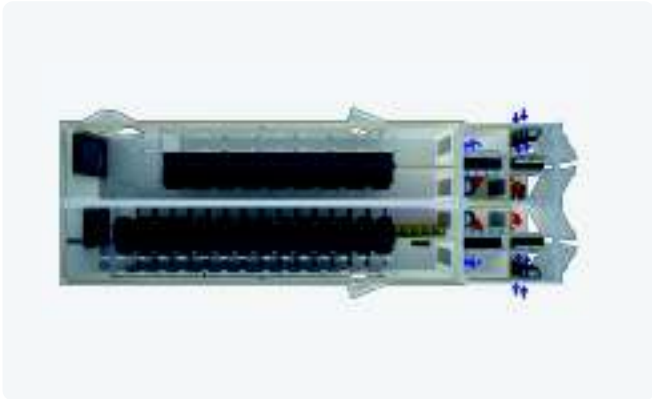

Natural Free Cooling is a solution which dramatically reduces the energy consumption within the data center, generates savings and helps your organization be energy efficient.

Allows free cooling with temperatures up to 24° C without any external chiller and without any input from outside air. This provides dramatic energy savings with a ROI of less than 18 months.

This system avoid cross contamination. The interior of the data center remains as an airtight enclosure unaffected by external environmental conditions such as humidity, pollution, corrosive gases and particles.



IDEAL FOR

- Containerized applications
- Modular data center
- High scalability and efficiency
- Reduces the energy consumption

RNFC Retrofit Natural Free Cooling

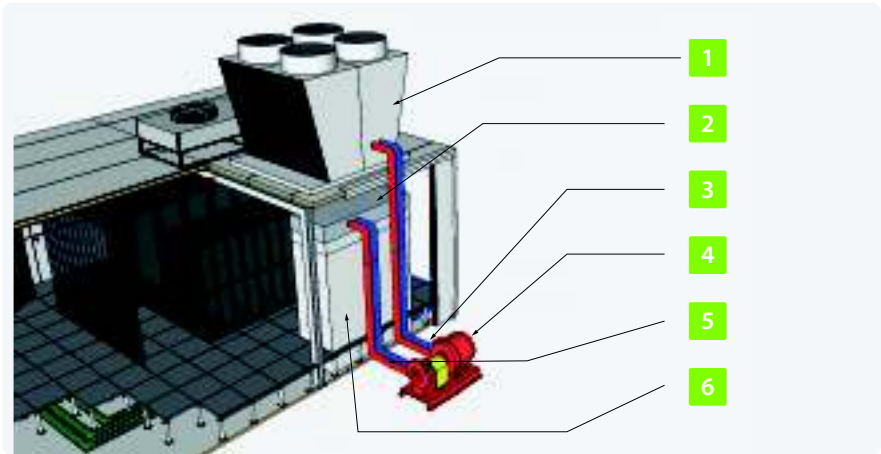

- 1. DRY COOLER
- 2. COIL
- 3. SUPPLY
- 4. PUMP MODULE
- 5. RETURN
- 6. CRAC UNIT

IDEAL FOR

Existing data centers	Optimize cooling performances
Additional cooling supply	Lower energy consumption

RNFC is designed to improve existing traditional cooling in a data center with minimal impact.

RNFC installation for Free Cooling at temperatures up to 19°C. RNFC consists of a passive coil installed at the return air entrance of AC machines in data room, with water circuit and pump to external heat exchanger (dry cooler) and control PLC. If the external temperature is < 16°C, PLC starts the circuit and cools the hot return air, so the AC machines only boost the already cooled air and the compressor does NOT work. For external temperatures between 16°C and 19°C, an adiabatic solution is used, thus stretching the efficiency range.

HCX Hot Corridor eXchanger

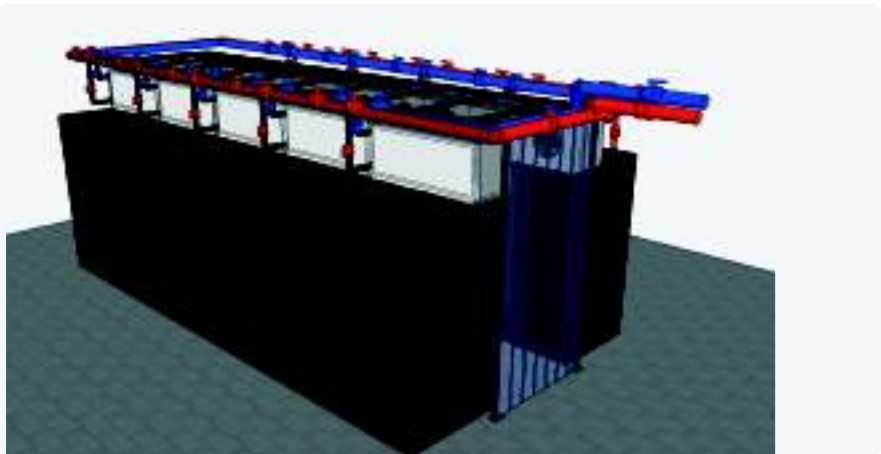

IDEAL FOR

Existing and new data centers	Increase energy efficiency
Increase rack density	Optimize data center space and layout

HCX is chilled water cooling Solution designed for optimized data center efficiency and adaptable to any corridor layout with multivendor rack equipment.

HCX works with higher water temperature and increases your data center cooling power on a non disruptive basis and without needing additional space nor changing the existing layout.

LOW FREQUENCY

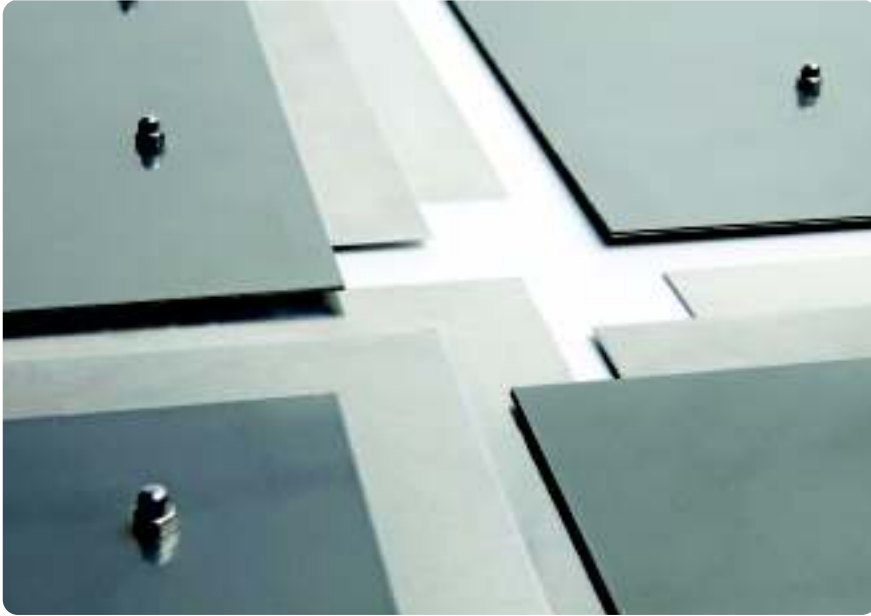

“SMART SHIELD” is a modular solution for EMF protection.

Electromagnetic shielding helps reduce the electromagnetic pollution in the environment.

IDEAL FOR

Easy installation & customizable sizes

10 year warranty

AST Modular's patented technology

Certified Solution

HIGH FREQUENCY



High Frequency is based on highly conductive materials which provides very consistent performances.

Standard 30dB Shielding solution (Soft-Tempest), which is cost effective, easy to install and secure. It decreases of more than 90% the potential risks caused by any EMI/RFI signal.

High Frequency complies with current IEC immunity standards, provides an EMI/RFI “clean” environment and it is ideal to protect your data center.

IDEAL FOR

Turn-key installation

> 100 dB protection

Fast deployment

Certified performance



SERVICES

Design services for modular and energy efficient Data Centers.

STRESS CHECK



Minimize the risk of failure and improve the health of your data center.

"IT Check" service. Checks the current state of a data center, its potential points of failure and areas of improvements.

IDEAL FOR

Security	Energy efficiency
Extend Data Center life cycle	Risk prevention

ENERGY EFFICIENCY

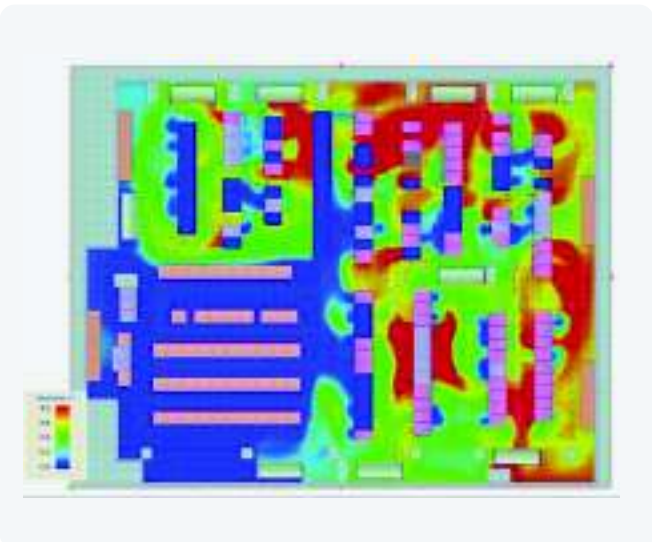

AST Modular's Energy Efficiency Services address cooling issues, thermal assessment, and electrical assessment critical points, connections, and operations of the electrical systems according to industry recognized best practices and standards.

Through the extensive use of data center simulation tools such as Computational Fluid Dynamics (CFD) we capture details and snapshots that display data center airflow, static pressure and temperature, providing visual documentation of hot spots that decrease data center availability and performance. Our Energy Efficiency Services evaluate the energy consumption of your data center and can implement one of our groundbreaking and ultra energy efficient cooling technologies to drastically cut your energy bill. Our assessment encompasses a comprehensive report which details the expected savings and how long it will take you to recover from the investment. (ROI)

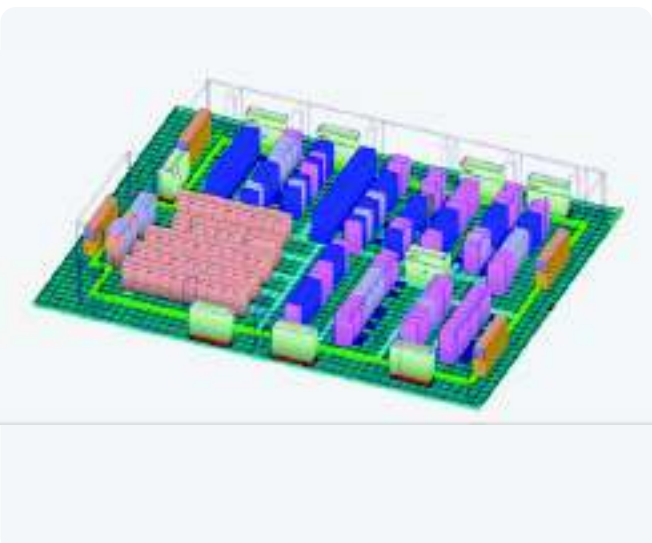

IDEAL FOR

Improve Data Center efficiency	Actions to implement in short/mid term
Reduce Data Center energy consumption	Fast Return On the Investment

WORLDWIDE PARTNERS

EUROPE

Austria
Belgium
Bosnia
Bulgaria
Croatia
Czech republic
Denmark
Finland
Greece
Iceland
Italy
Latvia
Netherlands
Norway
Poland
Portugal
Serbia
Slovakia
Spain
Sweden
Switzerland
Turkey
United kingdom

NORTH AMERICA

Canada
Costa Rica
Mexico
Puerto Rico
Usa

SOUTH AMERICA

Argentina
Brazil

ASIA

Israel
Japan
Malaysia
Russia
Thailand
United Arab Emirates

AFRICA

Libya
Nigeria

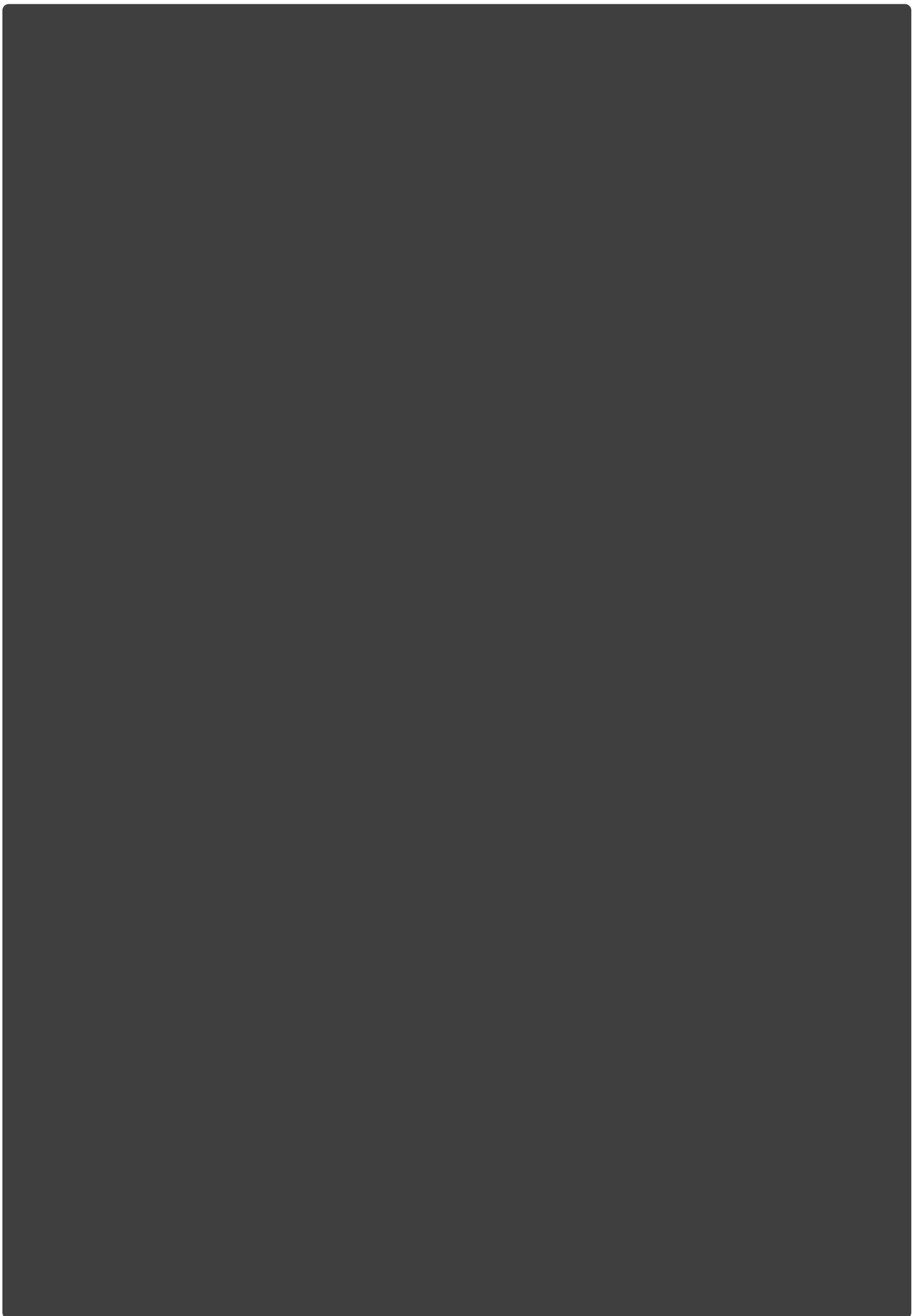

**EMEA**

AST Modular EMEA
43, Albert Einstein
E-08940 Cornellà de Llobregat
Barcelona, Spain
Tel: +34 93 475 14 81
info@astmodular.com

NORTH AMERICA

AST Modular North America
15281 Northwest 33rd Place
Opa-locka, FL 33054, US
Tel: +1 954 753-4081
Mobile: +1 330 472 2800
joseba.calvo@astmodular.com

SOUTH AMERICA

AST Modular South America
Rua Maestro João Gomes de Araújo, 106
Água Fria, 02332-020 - São Paulo - SP
Tel: +55 11 2976 5701
Mobile: +55 11 9635 9051
jayne.cosceli@astmodular.com

APAC

AST Modular Asia Pacific
37th Floor, Singapore Land
Tower, 50 Raffles Place
048623 Singapore
Tel: +65 6733 5900
erik.ching@astmodular.com